

REVISIONS						
ZONE	LTR	DESCRIPTION	CHANGE No	DATE	BY	APPR'D
AA		INITIAL RELEASE	DR51234	08SEP15	RMB	BLM
AB		REMOVE EXTRA GRND WIRE FRM VIEWS	DR55833	13JAN16	RMB	BLM

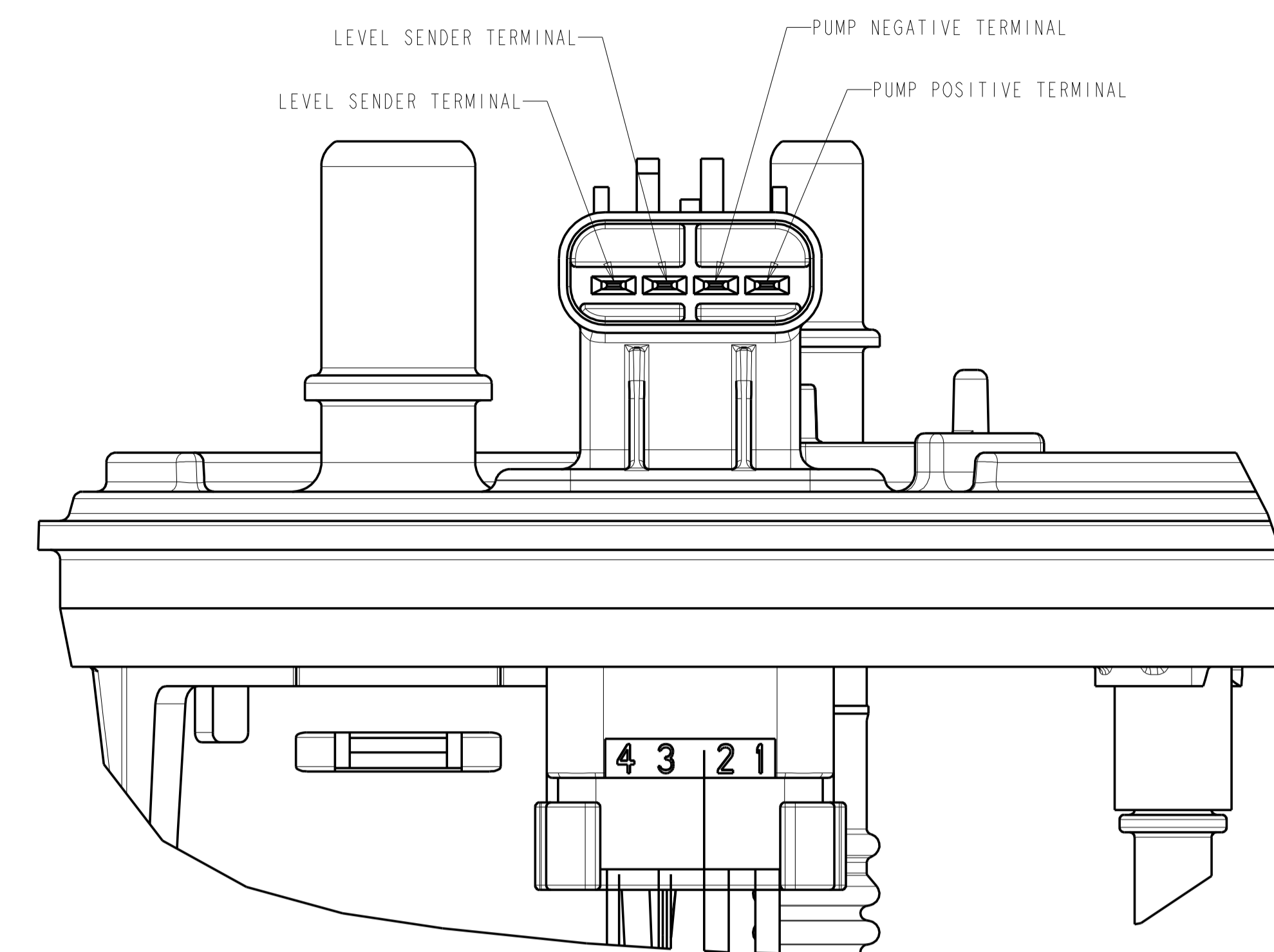

VIEW IN DIRECTION OF ARROW "X"
E-CONNECTOR PINOUT
SCALE 2:1

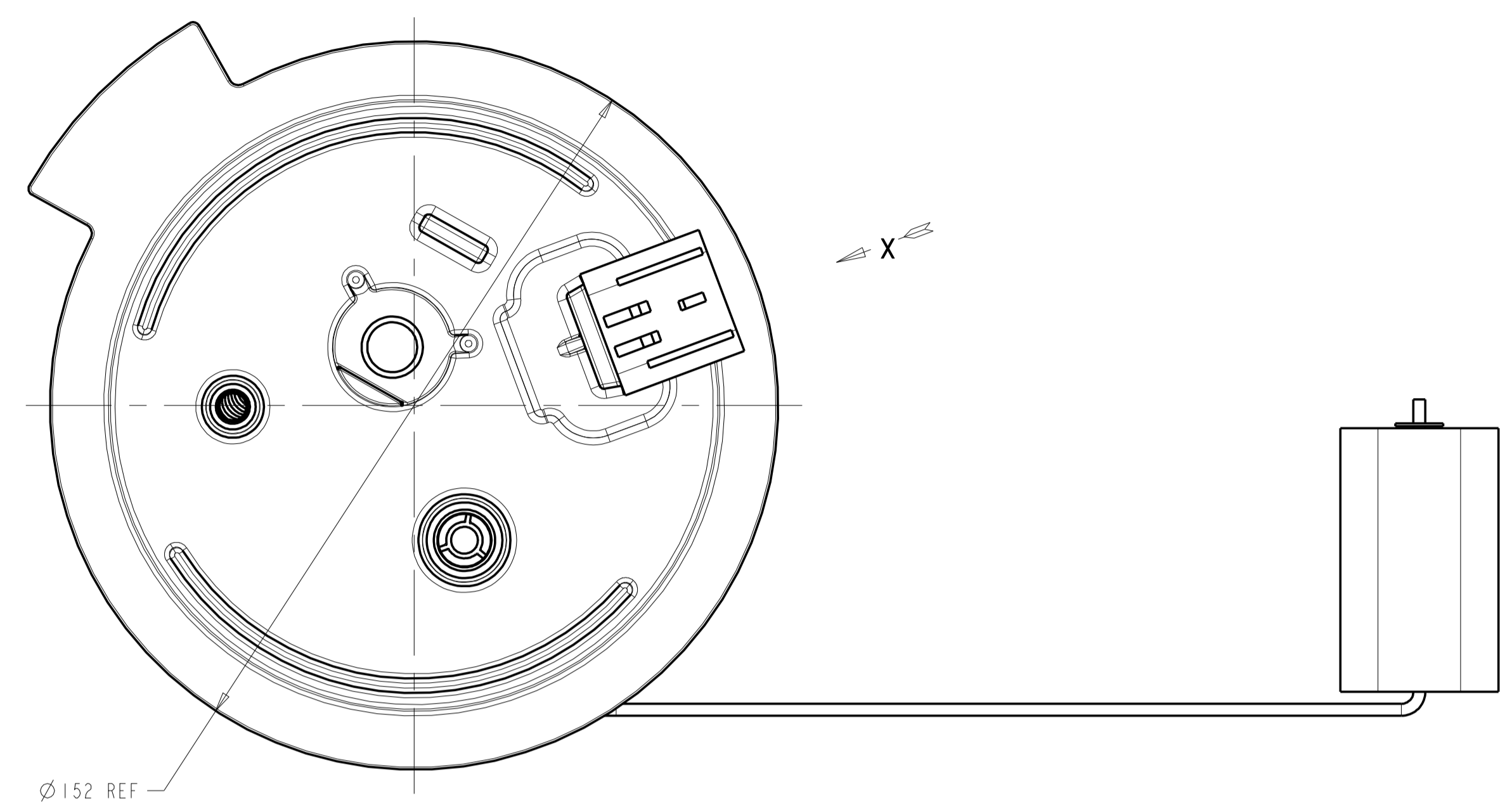
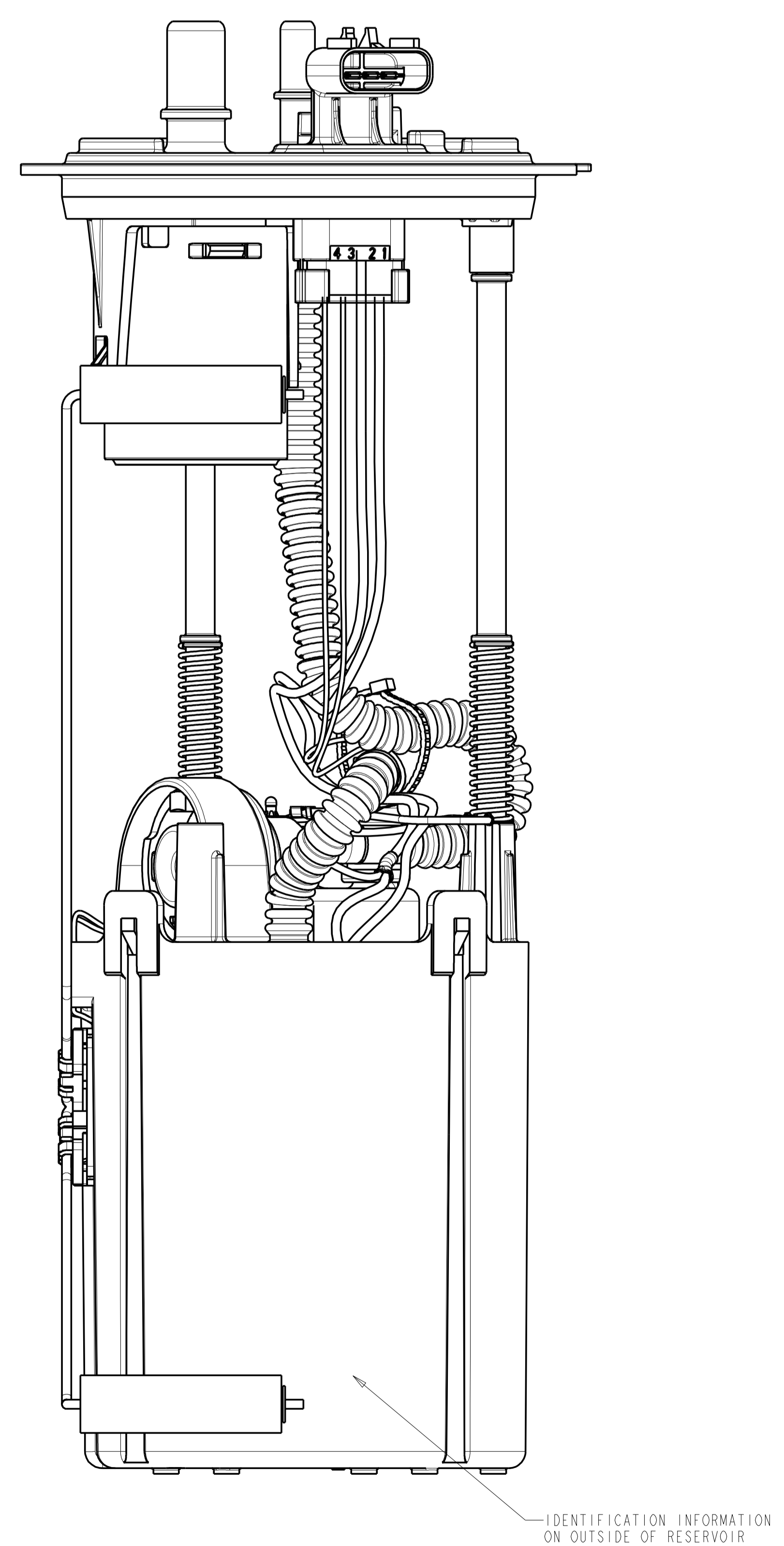
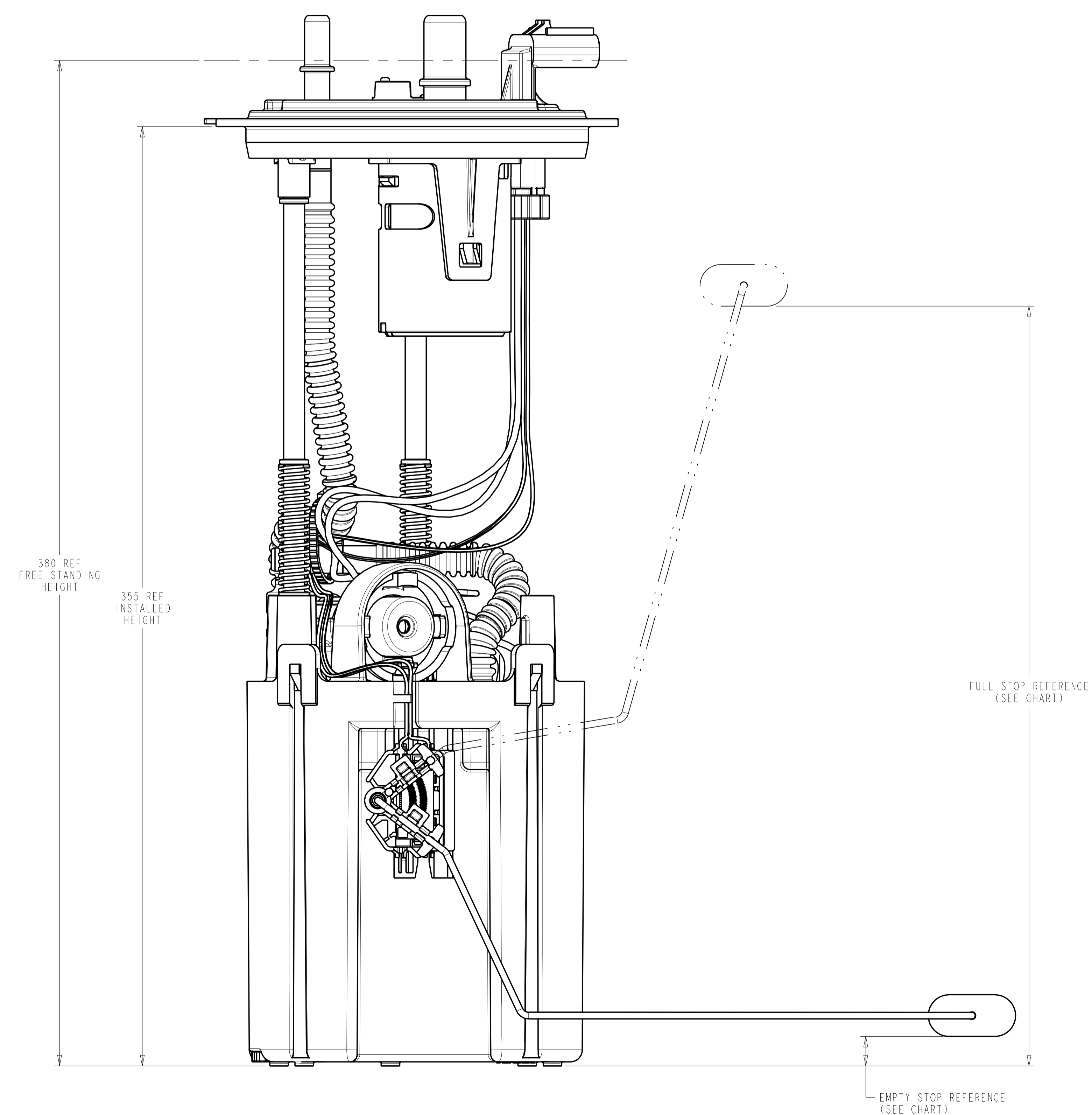

FLOAT POSITION	HEIGHT (mm)	RESISTANCE (Ohms)
FULL STOP	287.3 REF	10 ± 2
EMPTY STOP	10.9 REF	180 ± 4

NOTES:

- CHANGE IN DESIGN, COMPOSITION, LOCATION OR PROCESSING FROM THE PART PREVIOUSLY APPROVED FOR PRODUCTION REQUIRES PRIOR APPROVAL BY TI AUTOMOTIVE.
- SPECIAL CUSTOMER PACKAGING REQUIREMENTS MAY CALL FOR THE ADDITION OF SPECIFIC LABELS NOT SHOWN ON THIS DRAWING.
- SHOWN WIRE ROUTING MAY DIFFER FROM FINISHED PRODUCT.
- MODULE TO BE PACKAGED USING COMPONENTS NOTED ON BOM SO THAT CONTAMINATION FROM FOREIGN MATERIAL IS PREVENTED:
 - PLUG PROTECTORS ON PORTS
 - POLYBAG

▽	DENOTES SAFETY CHARACTERISTIC
◇	DENOTES SIGNIFICANT CHARACTERISTIC
◆	DENOTES HIGH IMPACT CHARACTERISTIC

ALL DIMENSIONS ARE IN MILLIMETERS

DO NOT SCALE

DECIMAL TOLERANCES UNLESS OTHERWISE SPECIFIED
ONE PLACE = 0.25 TWO PLACE = 0.13 ANGLES = 1°

THIRD ANGLE PROJECTION

DIMENSIONS IN ACCORDANCE WITH ASME Y14.5 - 2009

TI Automotive 630 COLUMBIA ST. CARO, MI 48723 +1 989.673.7127

ENGINEER	B. WIDDLETON	DESIGNER	R. BRUBAKER
DES. MANAGER		SCALE	1:1
DESIGNER	R. BRUBAKER	SHEET NO.	1 OF 1

CAD SYSTEM: PROVE

REFERENCE TITLES:
000113888/AA

P/W REFERENCE:
2D: AR0039588/AB
3D: AR0039586/AB

DRAWING NAME:
FUEL MOD(AFTMKT F250-450 11-14 SUPER DUTY)

DATE: AD DRAWING NUMBER: TU2000HP