

REVISIONS						
ZONE	LTR	DESCRIPTION	CHANGE No	DATE	BY	APPR'D
	AA	INITIAL RELEASE	DR72731	11OCT18	RMB	BLL
	AB	INLET ASM 0213460 STD CARB PIN	C'13826	17OCT22	RMB	BLM
5-E	AC	AC1 DBTC0031 MAGNETS WERE 134-31	83524	26JAN23	JTK	MLM

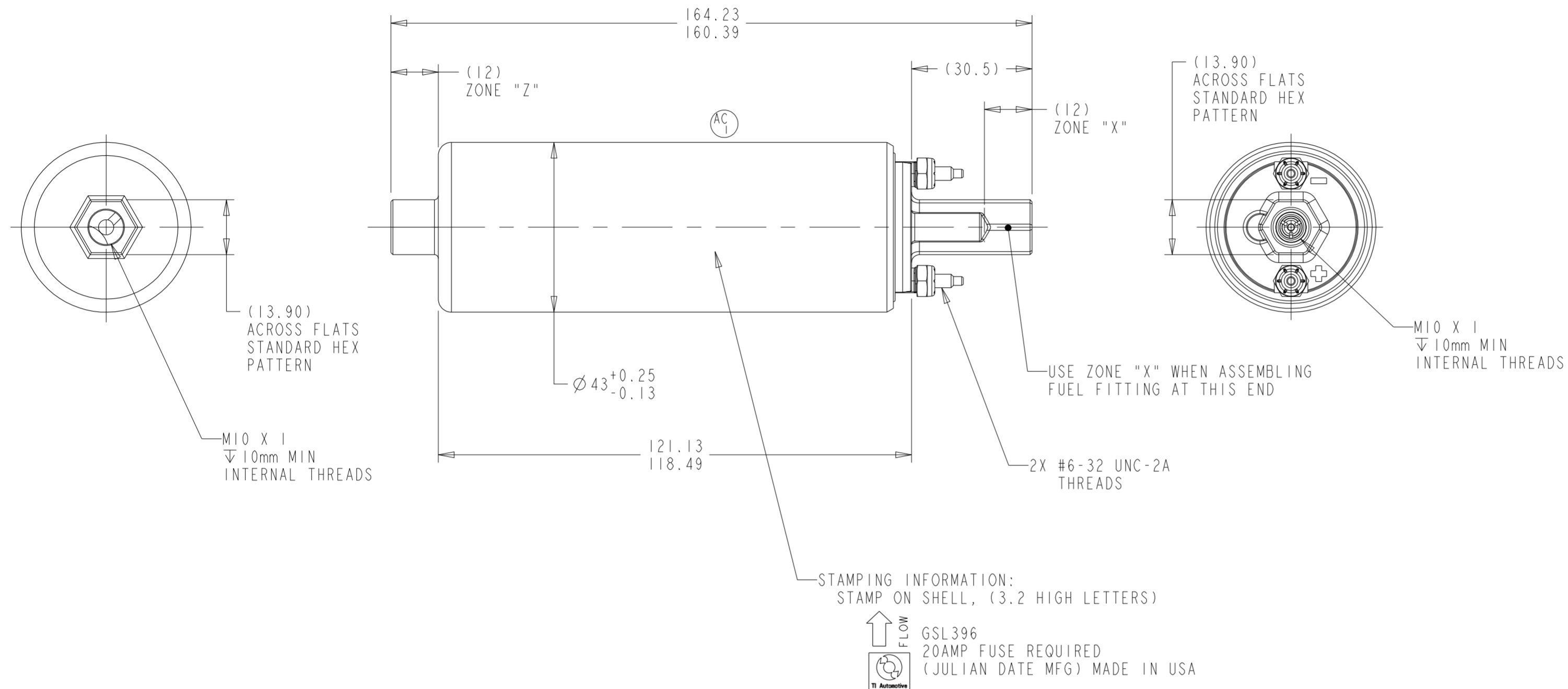

NOTES:

- PUMPS SHALL POSSESS IDENTIFICATION MARK TO SIGNIFY PASSING AIR LEAK TEST
- ORIENTATION OF OUTLET FITTING TO INLET FITTING WILL BE RANDOM
- PUMPS SHALL BE SUITABLY PACKAGED TO PREVENT CONTAMINATION WITH FOREIGN MATERIAL
- ASSEMBLY NOTE:

FITTING AND WIRE HARNESS TO BE ASSEMBLED BY THE CUSTOMER AS PER THE FOLLOWING:

DO NOT HOLD PUMP ON THE $\varnothing 43$ mm WHEN TORQUING FITTINGS

TO INSTALL FUEL FITTINGS ON BOTH ENDS OF THE PUMP, PLACE A WRENCH IN THE 12mm ZONE ON THE HEX ON THE END OF THE PUMP WHERE FITTING IS BEING INSTALLED. COPPER WASHER AND FITTING ARE INSTALLED TOGETHER. USING ANOTHER WRENCH, TORQUE FITTING TO 200 ± 10 IN-LB

WIRE HARNESS INSTALLATION REQUIRES TWO WRENCHES. PLACE FIRST WRENCH ON PRE-INSTALLED HEX NUT. THEN PLACE RING TERMINAL, LOCK WASHER AND SECOND HEX NUT ON TERMINAL POST. USING SECOND WRENCH, TORQUE TO 10 ± 1 IN-LB

METRIC ALL DIMENSIONS ARE IN MILLIMETERS			
DO NOT SCALE DECIMAL TOLERANCES UNLESS OTHERWISE SPECIFIED ONE PLACE ± 0.25 TWO PLACE ± 0.13 ANGLES $\pm 1^\circ$			
		THIRD ANGLE PROJECTION	
DIMENSIONS IN ACCORDANCE WITH ASME Y14.5 - 2009			
		630 COLUMBIA ST. CARO, MI 48723 +1 989.673.7727	
ENGINEER:	B. LEARMAN	10OCT2018	MATERIAL/SPECIFICATION: SEE NOTE
DESIGNER:	R. BRUBAKER	10OCT2018	
CAD SYSTEM: PRO/E	SCALE: 1:1	SHEET NO. 1 OF 1	
REFERENCE ID/REV.:	HJPS0396AC	2D PLM REFERENCE/REV.: AR0049701/AC	
REFERENCE ID/REV.:	000121541/AC	3D PLM REFERENCE/REV.: AR0049699/AC	
DRAWING NAME: FUEL PUMP OUTLINE (IN-LINE, .350 GEAR)			
SIZE:	A2	DRAWING NUMBER: GSL396	

KEY PRODUCT CHARACTERISTICS				
REFER TO TI AUTOMOTIVE GLOBAL ADVANCED QUALITY PLANNING DOCUMENT CW-4-ALL-411 FOR THE CLASSIFICATION AND CONTROL OF KEY PRODUCT CHARACTERISTICS				
TYPE OF CHARACTERISTIC	SAFETY	REGULATORY	FUNCTION	FUNCTION PROCESS
	SC	SC	SC	SC
NUMBER PER EACH CHARACTERISTIC	0	0	0	0
TOTAL NUMBER OF CHARACTERISTICS	0			
<small>TI AUTOMOTIVE CONFIDENTIAL AND PROPRIETARY - THIS DRAWING IS PROPERTY OF TI AUTOMOTIVE. TI AUTOMOTIVE CLAIMS PROPRIETARY RIGHTS IN THE SUBJECT MATTER SHOWN AND DESCRIBED ON THIS DRAWING AND RETAINS ALL INTELLECTUAL PROPERTY RIGHTS. THE DRAWING IS PROVIDED FOR REFERENCE PURPOSES ONLY AND ON THE EXPRESS CONDITION THAT IT WILL BE HELD IN CONFIDENCE. THIS DRAWING SHALL NOT BE DISCLOSED TO OTHERS OR USED FOR THE PURPOSE OF MANUFACTURE BY OR PROCUREMENT FROM OTHERS OF THE ARTICLE OR PART SHOWN WITHOUT TI AUTOMOTIVE'S EXPRESS WRITTEN CONSENT. NO LICENSE OR OTHER RIGHT IS GIVEN OR IMPLIED BY THE PROVISION OF THIS DRAWING TO RECIPIENT. COPYRIGHT, TI AUTOMOTIVE 2018. ALL RIGHTS RESERVED.</small>				