

REVISIONS						
ZONE	LTR	DESCRIPTION	CHANGE No	DATE	BY	APPR'D
		RELEASE FOR QUOTE	-----	02NOV98		CJB
		RELEASE FOR PRODUCTION	66281	22APR99	RMB	CJB
5-C	A	A1 MODIFIED STAMP INFO				
6-C		A2 118.83 WAS 118.95				
5-E		A3 161.63 WAS 162.05 157.79 158.07	67363	27FEB01	DRG	MMcK
5-C	B	REVISED STAMPING INFORMATION LOGO	67541	16JUL01	RMB	MMcK
8-B	C	C1 ADDED NOTE 4				
4-D		C2 ADDED DIMENSION				
6-E		C3 ADDED ZONE TO DIMENSION	67917	08APR02	RMB	MMcK
8E, 4D		C4 ADDED ZONE NOTES TO BOTH HEX ENDS				
4-C	D	REMOVED PATENT NUMBERS	71352	01MAY08	DRG	BLM
4-D	E	1080546 WAS 1080542	C'948	19AUG11	WDE	MMcK
5-D	F	000107170 NUT WAS 1340091	C'1474	18SEP12	WDE	MMcK
5-E	G	G1 000113267 WAS 000107170	77958			
6-D		G2 000103156 WAS 0160586	77961			
6-D		G3 000107879 WAS 1810643 & 108-208 WAS 108-209	78384	12MAY16	SLK	MMcK MAS
5-C	H	G4 UPDATED SHELL STAMP LOGO	C'3614			
5-E		G5 000005875 WAS 1080540	78761			
*** LETTER "I" NOT USED ***						
5-D	J	J1 000103154 WAS 1080546	79971	13JUL18	SLK	TLH
5-D	K	K1 DBTC0031 MAGNETS WERE 184-31	83524	25JAN23	JTK	MLM

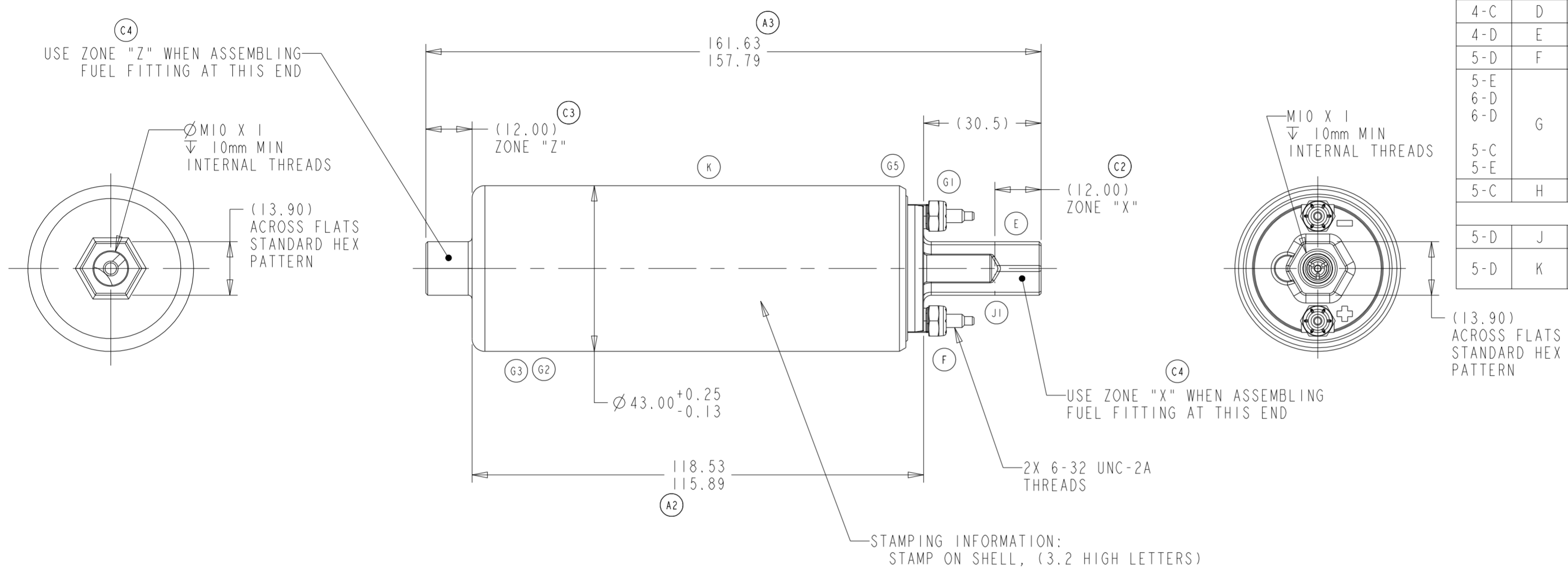

NOTES:

- 1) PUMPS SHALL POSSESS IDENTIFICATION MARK TO SIGNIFY PASSING AIR LEAK TEST
- 2) ORIENTATION OF OUTLET FITTING TO INLET FITTING WILL BE RANDOM
- 3) PUMPS SHALL BE SUITABLY PACKAGED TO PREVENT CONTAMINATION WITH FOREIGN MATERIAL

(C1) 4) ASSEMBLY NOTE:
FITTING AND WIRE HARNESS TO BE ASSEMBLED BY THE CUSTOMER AS PER THE FOLLOWING:

DO NOT HOLD PUMP ON THE Ø43mm WHEN TORQUING FITTINGS

TO INSTALL FUEL FITTINGS ON BOTH ENDS OF THE PUMP, PLACE A WRENCH IN THE 12mm ZONE ON THE HEX ON THE END OF THE PUMP WHERE FITTING IS BEING INSTALLED. COPPER WASHER AND FITTING ARE INSTALLED TOGETHER. USING ANOTHER WRENCH, TORQUE FITTING TO 200±10 IN-LB

WIRE HARNESS INSTALLATION REQUIRES TWO WRENCHES. PLACE FIRST WRENCH ON PRE-INSTALLED HEX NUT. THEN PLACE RING TERMINAL, LOCK WASHER AND SECOND HEX NUT ON TERMINAL POST. USING SECOND WRENCH, TORQUE TO 10±1 IN-LB

NOTES:

 GSL394
 20AMP FUSE REQUIRED
 (JULIAN DATE MFG) MADE IN USA

KEY PRODUCT CHARACTERISTICS			
REFER TO TI AUTOMOTIVE GLOBAL ADVANCED QUALITY PLANNING DOCUMENT CW-4-ALL-411 FOR THE CLASSIFICATION AND CONTROL OF KEY PRODUCT CHARACTERISTICS			
TYPE OF CHARACTERISTIC	SAFETY	REGULATORY	FUNCTION / FUNCTION PROCESS
NUMBER PER EACH CHARACTERISTIC	0	0	0
TOTAL NUMBER OF CHARACTERISTICS	0	0	0

TI AUTOMOTIVE CONFIDENTIAL AND PROPRIETARY - THIS DRAWING IS PROPERTY OF TI AUTOMOTIVE. TI AUTOMOTIVE CLAIMS PROPRIETARY RIGHTS IN THE SUBJECT MATTER SHOWN AND DESCRIBED ON THIS DRAWING AND RETAINS ALL INTELLECTUAL PROPERTY RIGHTS. THE DRAWING IS PROVIDED FOR REFERENCE PURPOSES ONLY AND ON THE EXPRESS CONDITION THAT IT WILL BE HELD IN CONFIDENCE. THIS DRAWING SHALL NOT BE DISCLOSED TO OTHERS OR USED FOR THE PURPOSE OF MANUFACTURE BY OR PROCUREMENT FROM OTHERS OF THE ARTICLE OR PART SHOWN WITHOUT TI AUTOMOTIVE'S EXPRESS WRITTEN CONSENT. NO LICENSE OR OTHER RIGHT IS GIVEN OR IMPLIED BY THE PROVISION OF THIS DRAWING TO RECIPIENT.
 COPYRIGHT, TI AUTOMOTIVE 2018, ALL RIGHTS RESERVED.

METRIC
 ALL DIMENSIONS ARE IN MILLIMETERS

DO NOT SCALE
 DECIMAL TOLERANCES UNLESS OTHERWISE SPECIFIED
 ONE PLACE ±0.25 TWO PLACE ±0.13 ANGLES ±1°

THIRD ANGLE PROJECTION
 DIMENSIONS IN ACCORDANCE WITH ASME Y14.5 - 2009

630 COLUMBIA ST.
 CARO, MI 48723
 +1 989.673.7727

ENGINEER:	C.BUMHOFFER	25MAR1999	MATERIAL/SPECIFICATION:
DESIGNER:	D.GILBERT	25MAR1999	
CAD SYSTEM: PRO/E	SCALE: 1:1	SHEET NO. OF	
REFERENCE ID/REV.:	HJPS0394F	2D PLM REFERENCE/REV.: AR0006012/AH	
REFERENCE ID/REV.:	000101875/AF	3D PLM REFERENCE/REV.: 000008532/A1	
DRAWING NAME: FUEL PUMP OUTLINE			
SIZE:	A2	DRAWING NUMBER:	GSL394