

REVISIONS

ZONE	LTR	DESCRIPTION	CHANGE No	DATE	BY	APPR'D
	AA	INITIAL RELEASE	DR95691	31MAY23	JTK	BLM

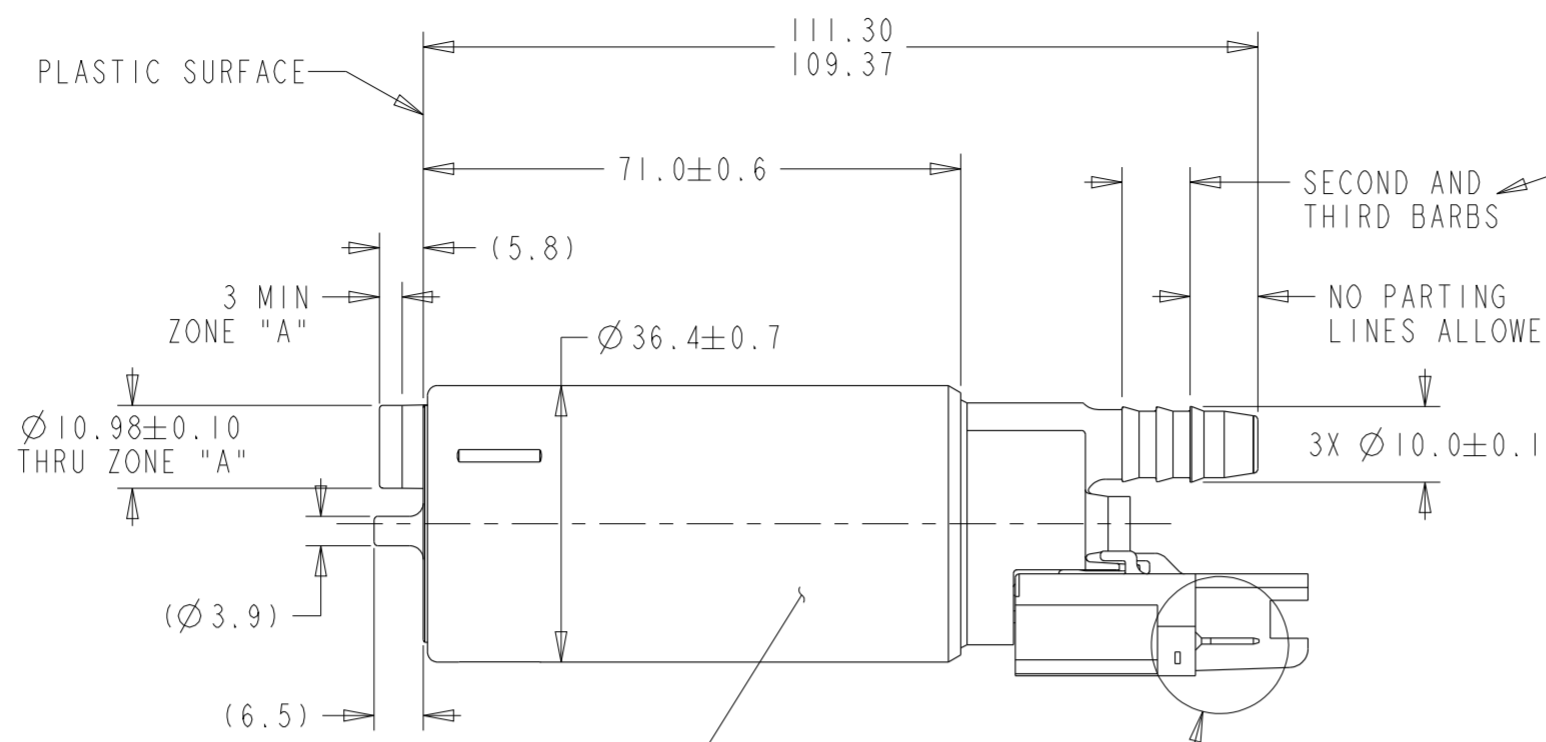

FLASH AND PARTING LINE MISMATCH

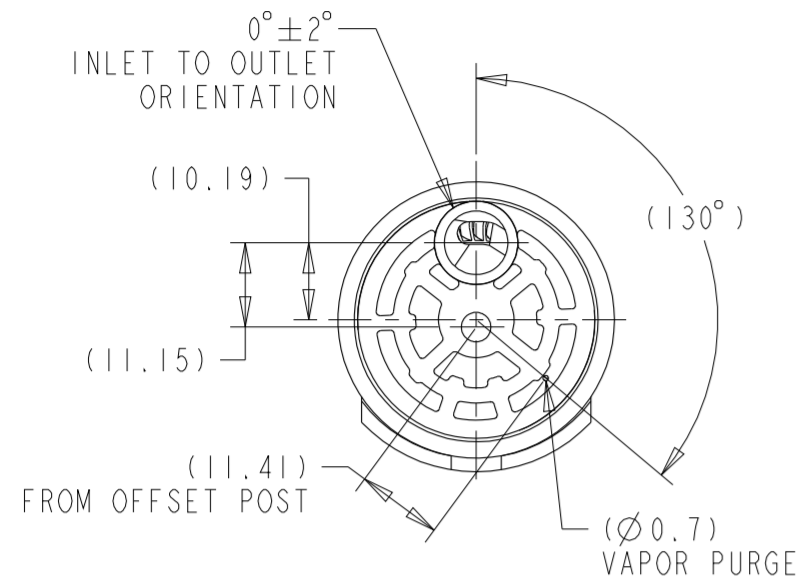
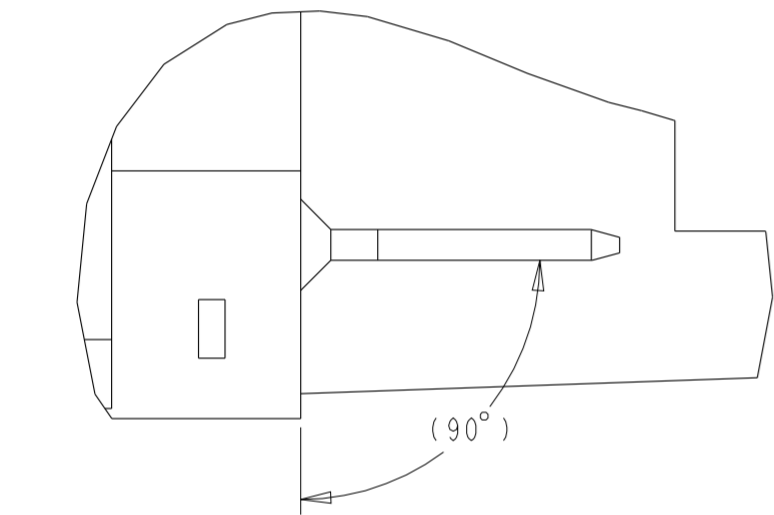
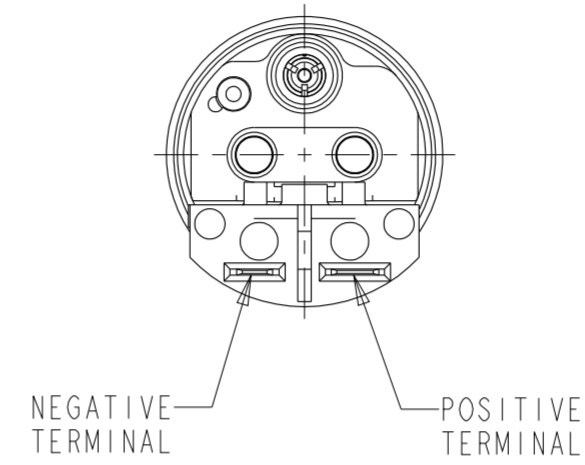
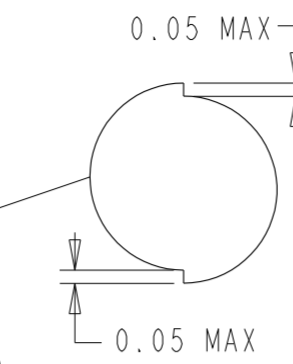

DETAIL Z
SCALE 5:1
(BOTH BLADES)

STAMPING INFORMATION:
STAMP ON SHELL, (3.2 HIGH LETTERS)



F10000377
HJQG0119XX ("XX" IS CURRENT REVISION)
(JULIAN DATE MFG) MADE IN USA

NOTES:

- PUMP TO BE SUITABLY PACKAGED TO PREVENT CONTAMINATION WITH FOREIGN MATERIAL.
- CUSTOMER MUST FOLLOW TI AUTOMOTIVE SPECIFICATION S-448 WHEN HANDLING THIS PUMP.
- TERMINAL BLADES DESIGNED TO SAE J858g TYPE 1B EXCEPT FOR DIMENSION G (THICKNESS) WHICH IS 0.81.
- MINIMUM RECOMMENDED WIRE GAGE: 14.
- MODEL: TI.9.
- RFI: DIN 5.

KEY PRODUCT CHARACTERISTICS

REFER TO TI AUTOMOTIVE GLOBAL ADVANCED QUALITY PLANNING DOCUMENT CW-4-ALL-411 FOR THE CLASSIFICATION AND CONTROL OF KEY PRODUCT CHARACTERISTICS

TYPE OF CHARACTERISTIC	SAFETY	REGULATORY	FUNCTION	FUNCTION PROCESS
NUMBER PER EACH CHARACTERISTIC	SC	SC	SC	SC
TOTAL NUMBER OF CHARACTERISTICS	1	1	1	1

TI AUTOMOTIVE CONFIDENTIAL AND PROPRIETARY - THIS DRAWING IS PROPERTY OF TI AUTOMOTIVE. TI AUTOMOTIVE CLAIMS PROPRIETARY RIGHTS IN THE SUBJECT MATTER SHOWN AND DESCRIBED ON THIS DRAWING AND RETAINS ALL INTELLECTUAL PROPERTY RIGHTS. THE DRAWING IS PROVIDED FOR REFERENCE PURPOSES ONLY AND ON THE EXPRESS CONDITION THAT IT WILL BE HELD IN CONFIDENCE. THIS DRAWING SHALL NOT BE DISCLOSED TO OTHERS OR USED FOR THE PURPOSE OF MANUFACTURE BY OR PROCUREMENT FROM OTHERS OF THE ARTICLE OR PART SHOWN WITHOUT TI AUTOMOTIVE'S EXPRESS WRITTEN CONSENT. NO LICENSE OR OTHER RIGHT IS GIVEN OR IMPLIED BY THE PROVISION OF THIS DRAWING TO RECIPIENT.
COPYRIGHT, TI AUTOMOTIVE 2018. ALL RIGHTS RESERVED.

METRIC
ALL DIMENSIONS ARE IN MILLIMETERS

DO NOT SCALE
DECIMAL TOLERANCES UNLESS OTHERWISE SPECIFIED
ONE PLACE ±0.25 TWO PLACE ±0.13 ANGLES ±1°

THIRD ANGLE PROJECTION
DIMENSIONS IN ACCORDANCE WITH ASME Y14.5 - 2009

TI Automotive
630 COLUMBIA ST.
CARO, MI 48723
+1 989.673.7727

ENGINEER:	B.MIDDLETON	31MAY23	MATERIAL/SPECIFICATION:	SEE NOTES
DESIGNER:	J.KULIGOWSKI	31MAY23		
CAD SYSTEM: PRO/E	SCALE: 1:1	SHEET NO. 1 OF 1		
REFERENCE ID/REV.:	HJQG0119	2D PLM REFERENCE/REV.: AR3105786/AA		
REFERENCE ID/REV.:	300114808/AA	3D PLM REFERENCE/REV.: AR3105784/AA		
DRAWING NAME: FUEL PUMP OUTLINE				
SIZE:	A2	DRAWING NUMBER: F10000377		