

REVISIONS						
ZONE	LTR	DESCRIPTION	CHANGE No	DATE	BY	APPR'D
	AA	INITIAL RELEASE	DR95691	31MAY23	JTK	BLM

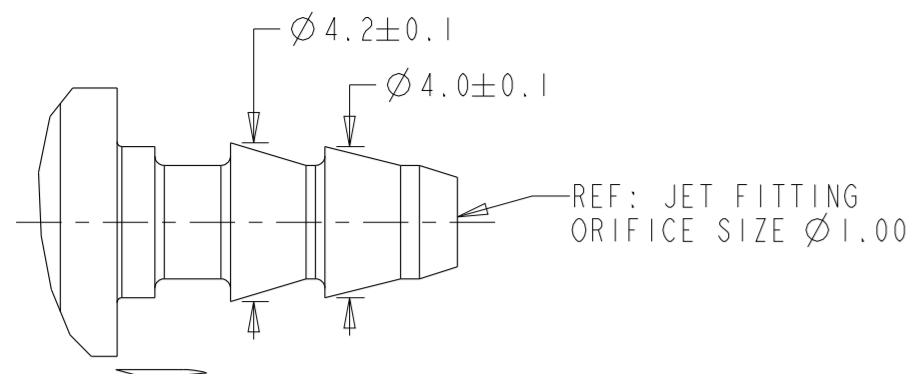

DETAIL Y
SCALE 5:1

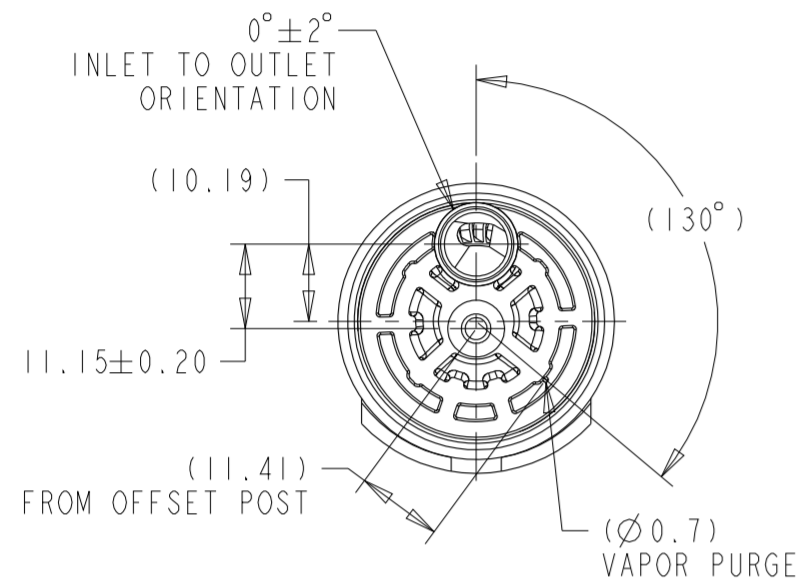

DETAIL Z
SCALE 5:1
(BOTH BLADES)

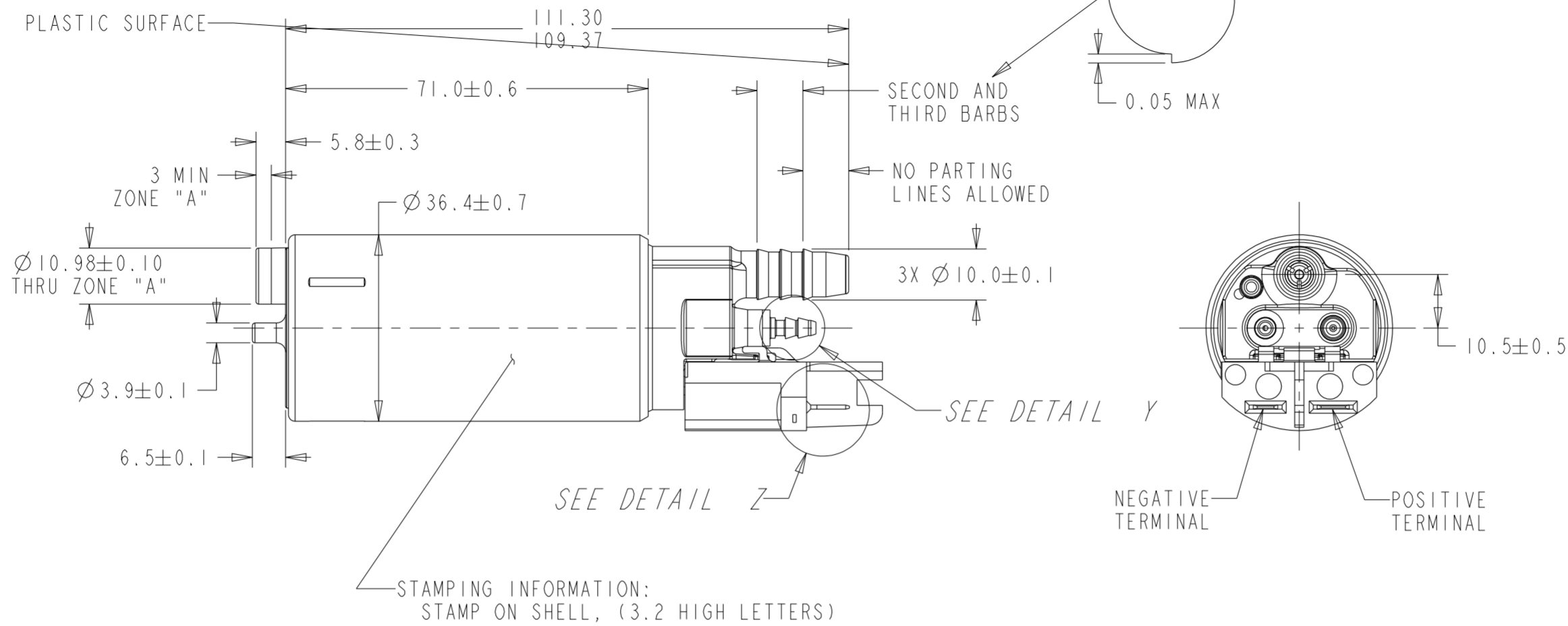
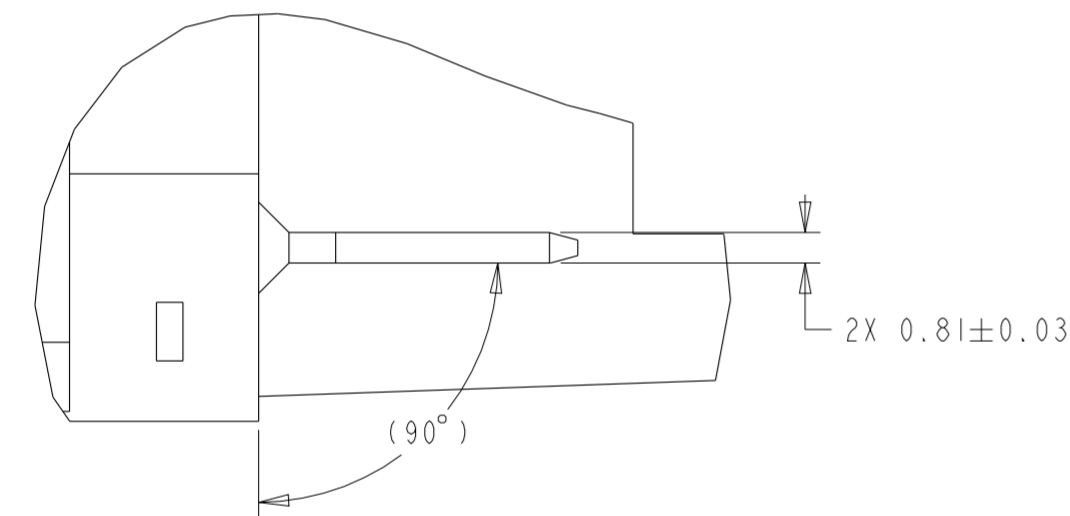

F10000376
HJQG0118XX ("XX" IS CURRENT REVISION)
(JULIAN DATE MFG) MADE IN USA

NOTES:

1. PUMP TO BE SUITABLY PACKAGE TO PREVENT CONTAMINATION WITH FOREIGN MATERIAL.
2. CUSTOMER MUST FOLLOW TI AUTOMOTIVE SPECIFICATION S-448 WHEN HANDLING THIS PUMP.
3. TERMINAL BLADES DESIGNED TO SAE J858a TYPE 1B EXCEPT FOR DIMENSION G (THICKNESS) WHICH IS 0.81.
4. MINIMUM RECOMMENDED WIRE GAGE: 14
5. MODEL: TI.9HF
6. RFI: DIN 5.

KEY PRODUCT CHARACTERISTICS			
REFER TO TI AUTOMOTIVE GLOBAL ADVANCED QUALITY PLANNING DOCUMENT CW-4-ALL-411 FOR THE CLASSIFICATION AND CONTROL OF KEY PRODUCT CHARACTERISTICS			
TYPE OF CHARACTERISTIC	SAFETY	REGULATORY	FUNCTION / FUNCTION PROCESS
NUMBER PER EACH CHARACTERISTIC	SC	SC	SC
TOTAL NUMBER OF CHARACTERISTICS	1	1	1

TI AUTOMOTIVE CONFIDENTIAL AND PROPRIETARY - THIS DRAWING IS PROPERTY OF TI AUTOMOTIVE. TI AUTOMOTIVE CLAIMS PROPRIETARY RIGHTS IN THE SUBJECT MATTER SHOWN AND DESCRIBED ON THIS DRAWING AND RETAINS ALL INTELLECTUAL PROPERTY RIGHTS. THE DRAWING IS PROVIDED FOR REFERENCE PURPOSES ONLY AND ON THE EXPRESS CONDITION THAT IT WILL BE HELD IN CONFIDENCE. THIS DRAWING SHALL NOT BE DISCLOSED TO OTHERS OR USED FOR THE PURPOSE OF MANUFACTURE BY OR PROCUREMENT FROM OTHERS OF THE ARTICLE OR PART SHOWN WITHOUT TI AUTOMOTIVE'S EXPRESS WRITTEN CONSENT. NO LICENSE OR OTHER RIGHT IS GIVEN OR IMPLIED BY THE PROVISION OF THIS DRAWING TO RECIPIENT.
COPYRIGHT, TI AUTOMOTIVE 2018. ALL RIGHTS RESERVED.

METRIC
ALL DIMENSIONS ARE IN MILLIMETERS

DO NOT SCALE
DECIMAL TOLERANCES UNLESS OTHERWISE SPECIFIED
ONE PLACE ±0.25 TWO PLACE ±0.13 ANGLES ±1°

THIRD ANGLE PROJECTION
DIMENSIONS IN ACCORDANCE WITH ASME Y14.5 - 2009

630 COLUMBIA ST.
CARO, MI 48723
+1 989.673.7727

TI Automotive

ENGINEER:	B.MIDDLETON	31MAY23	MATERIAL/SPECIFICATION:
DESIGNER:	J.KULIGOWSKI	31MAY23	
CAD SYSTEM: PRO/E	SCALE: 1:1	SHEET NO. 1 OF 1	
REFERENCE ID/REV.:	HJQG0118	2D PLM REFERENCE/REV.: AR31057344/AA	
REFERENCE ID/REV.:	300114807/AA	3D PLM REFERENCE/REV.: AR3105732/AA	
DRAWING NAME: FUEL PUMP OUTLINE			
SIZE:	A2	DRAWING NUMBER:	F10000376