

REVISIONS

ZONE	LTR	DESCRIPTION	CHANGE No	DATE	BY	APPR'D
	AA	INITIAL RELEASE	---	17MAY19	RMB	AP

FILTER GROUP "A"

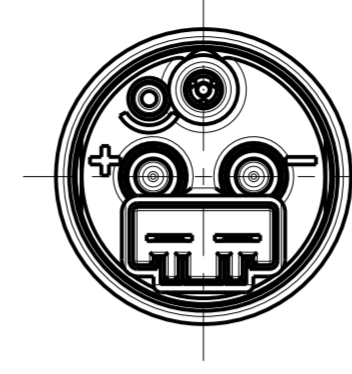
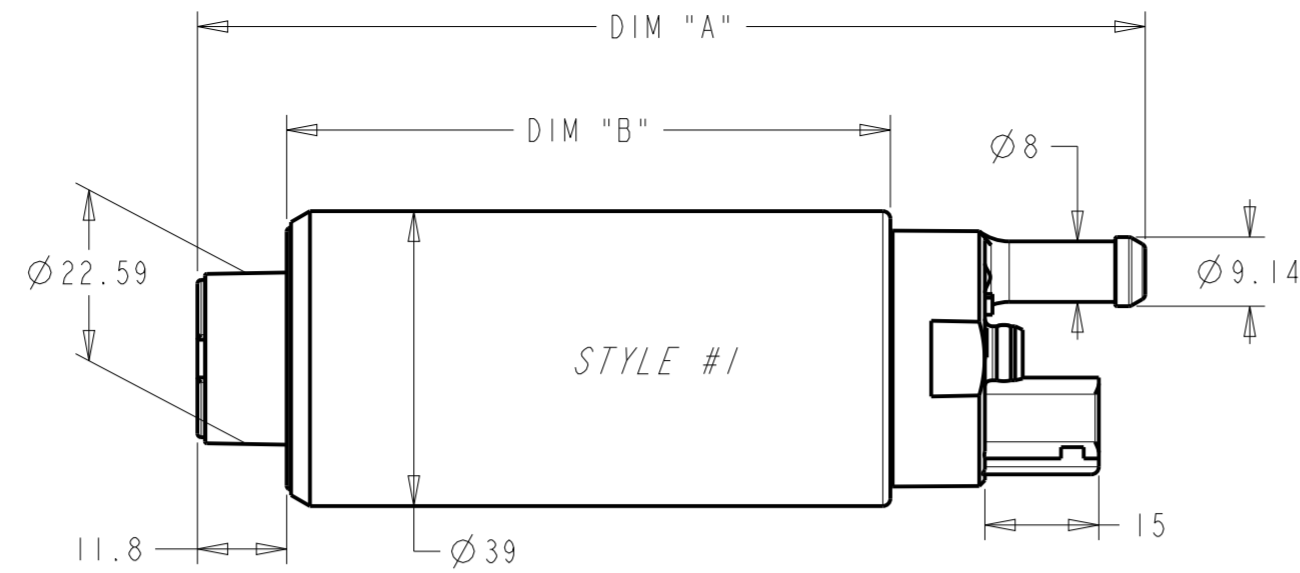
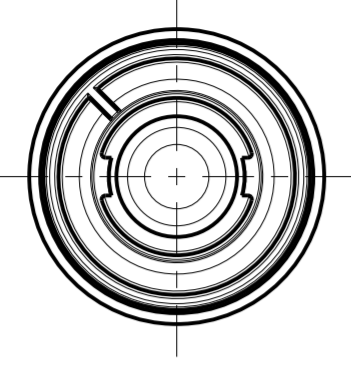

FILTER GROUP "B"

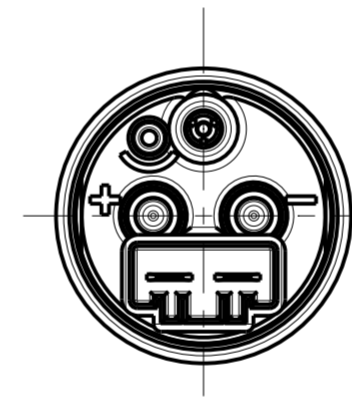
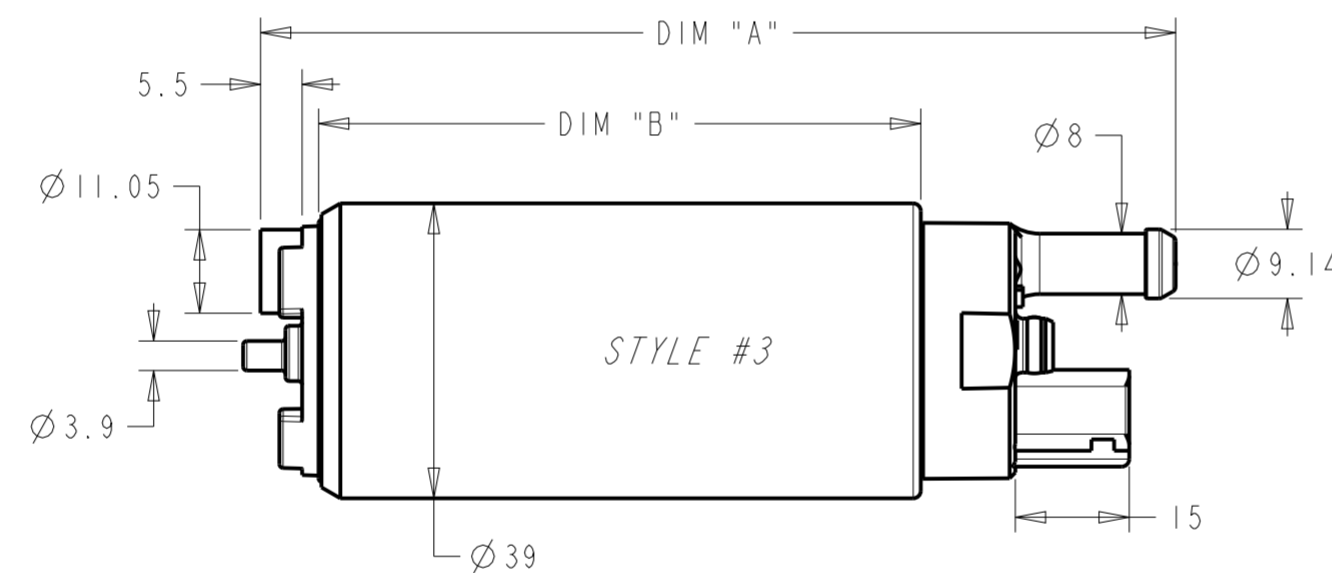
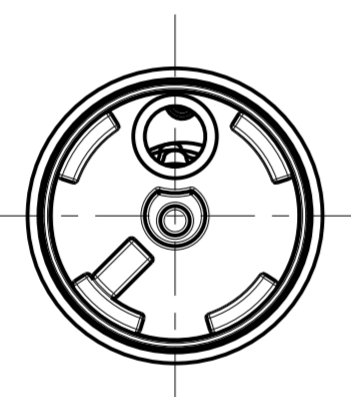
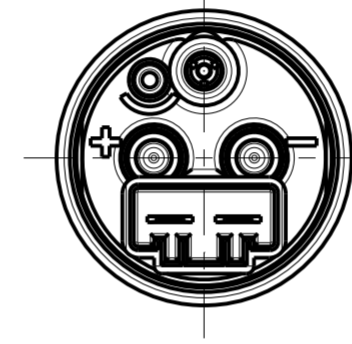
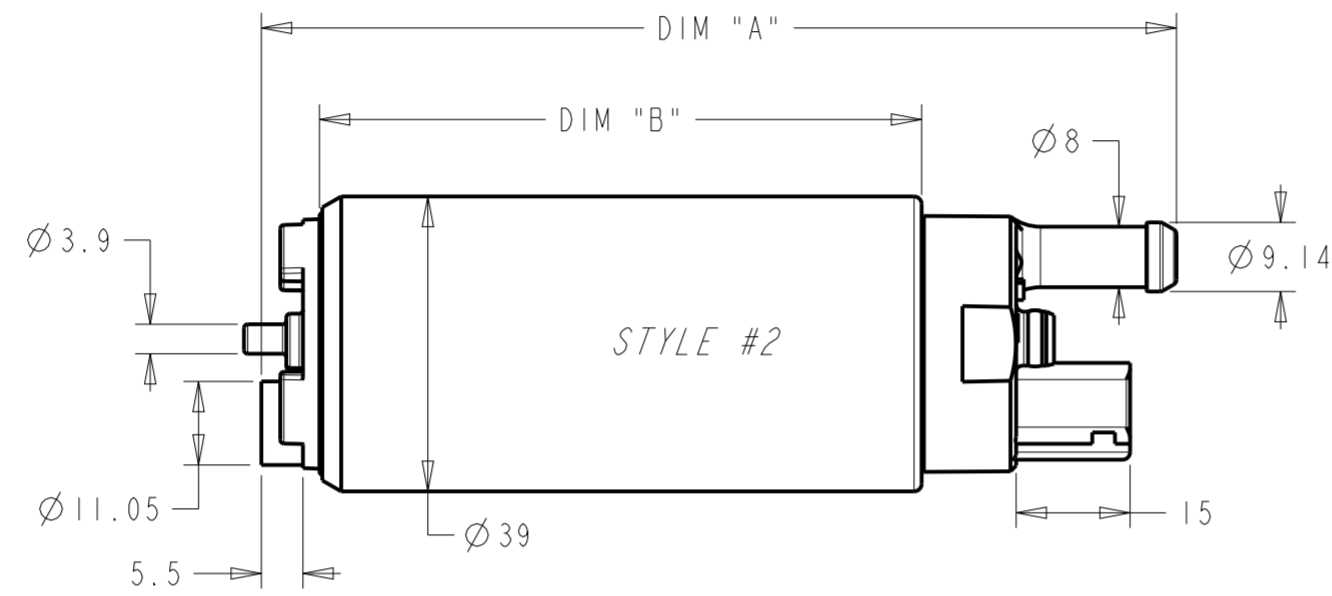
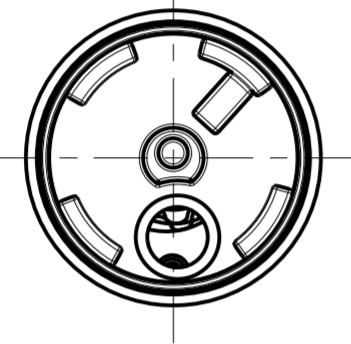

P/N	GSS242	GSS250	GSS278	GSS307	GSS315	GSS317	GSS340	GSS341	GSS342	F20000311	F20000312	F20000313
STYLE	#1	#3	#2	#1	#2	#3	#1	#2	#3	#1	#2	#3
DIM "A"	126.75 mm	122.43 mm	122.43 mm	128.08 mm	123.76 mm	123.76 mm	126.75 mm	122.43 mm	122.43 mm	126.75 mm	122.43 mm	122.43 mm
DIM "B"	81.4 mm	81.2 mm	81.2 mm	82.73 mm	82.53 mm	82.53 mm	81.4 mm	81.2 mm	81.2 mm	81.4 mm	81.2 mm	81.2 mm

METRIC
ALL DIMENSIONS ARE IN MILLIMETERS

DO NOT SCALE
DECIMAL TOLERANCES UNLESS OTHERWISE SPECIFIED
~~ONE PLACE ±0.25 TWO PLACE ±0.13 ANGLES ±1°~~

THIRD ANGLE PROJECTION
DIMENSIONS IN ACCORDANCE WITH ASME Y14.5 - 2009

TI Automotive
630 COLUMBIA ST.
CARO, MI 48723
+1 989.673.7727

ENGINEER:	A. PECKHAM	06MAY2019	MATERIAL/SPECIFICATION:	N/A
DESIGNER:	R. BRUBAKER	06MAY2019		
CAD SYSTEM:	PRO/E	SCALE: 1:1	SHEET NO. OF	
REFERENCE ID/REV.:	2D PLM REFERENCE/REV.:			
REFERENCE ID/REV.:	3D PLM REFERENCE/REV.:			
DRAWING NAME: GEN2 GEAR PUMP FAMILY				
SIZE:	A2	DRAWING NUMBER: GSS - G2 SERIES		

KEY PRODUCT CHARACTERISTICS

REFER TO TI AUTOMOTIVE GLOBAL ADVANCED QUALITY PLANNING DOCUMENT CP-4-ALL-411 FOR THE CLASSIFICATION AND CONTROL OF KEY PRODUCT CHARACTERISTICS

TYPE OF CHARACTERISTIC	SAFETY	REGULATORY	FUNCTION	FUNCTION PROCESS
NUMBER PER EACH CHARACTERISTIC	0	0	0	0
TOTAL NUMBER OF CHARACTERISTICS	0	0	0	0

TI AUTOMOTIVE CONFIDENTIAL AND PROPRIETARY - THIS DRAWING IS PROPERTY OF TI AUTOMOTIVE. TI AUTOMOTIVE CLAIMS PROPRIETARY RIGHTS IN THE SUBJECT MATTER SHOWN AND DESCRIBED ON THIS DRAWING AND RETAINS ALL INTELLECTUAL PROPERTY RIGHTS. THE DRAWING IS PROVIDED FOR REFERENCE PURPOSES ONLY AND ON THE EXPRESS CONDITION THAT IT WILL BE HELD IN CONFIDENCE. THIS DRAWING SHALL NOT BE DISCLOSED TO OTHERS OR USED FOR THE PURPOSE OF MANUFACTURE BY OR PROCUREMENT FROM OTHERS OF THE ARTICLE OR PART SHOWN WITHOUT TI AUTOMOTIVE'S EXPRESS WRITTEN CONSENT. NO LICENSE OR OTHER RIGHT IS GIVEN OR IMPLIED BY THE PROVISION OF THIS DRAWING TO RECIPIENT.
COPYRIGHT, TI AUTOMOTIVE 2018. ALL RIGHTS RESERVED.